

CHICAGO

ladenkast

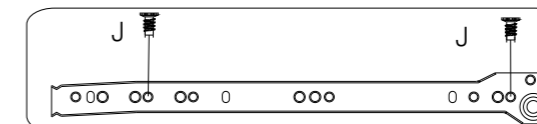
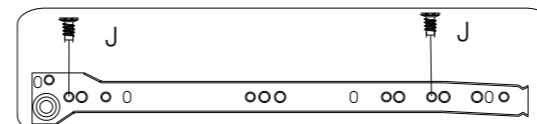
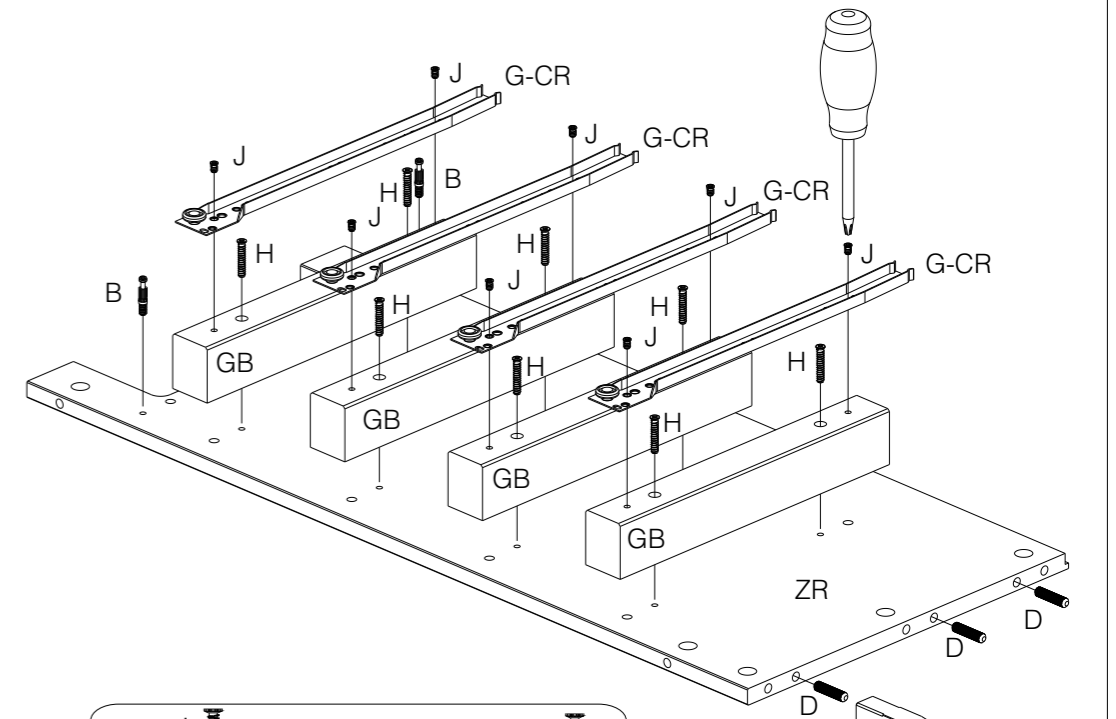
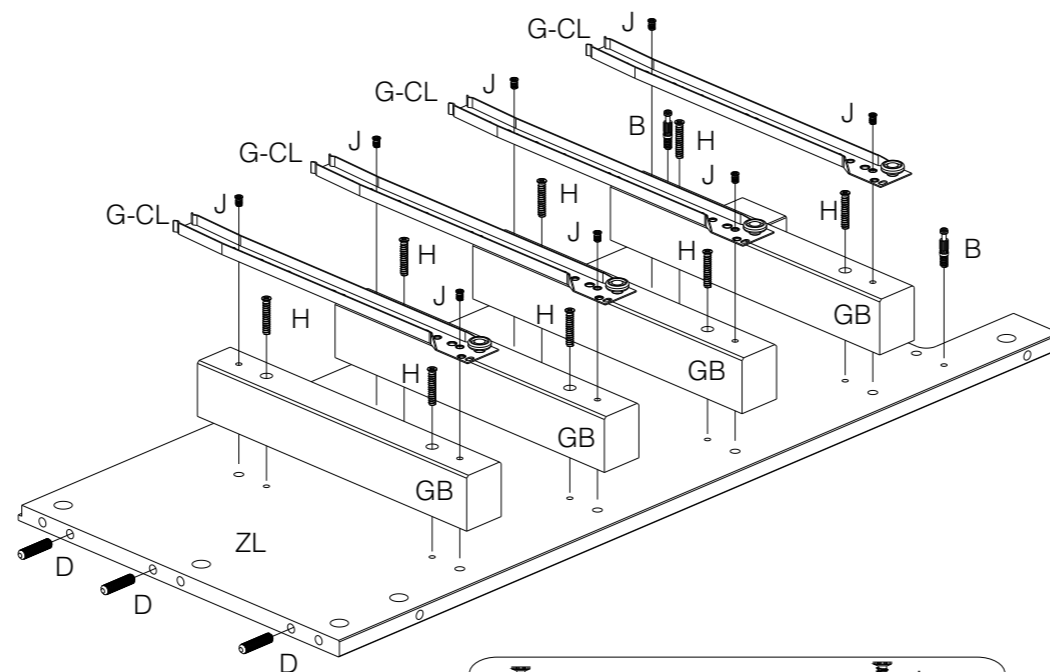
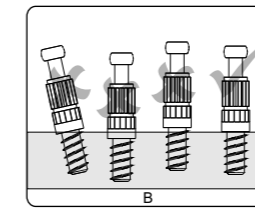
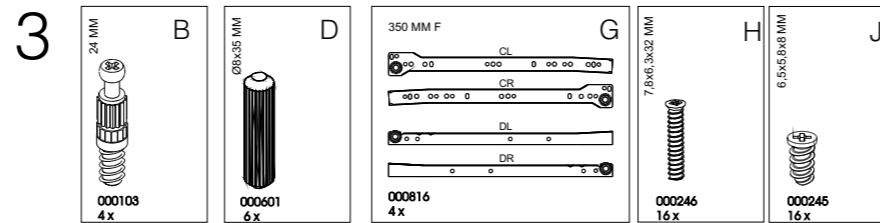
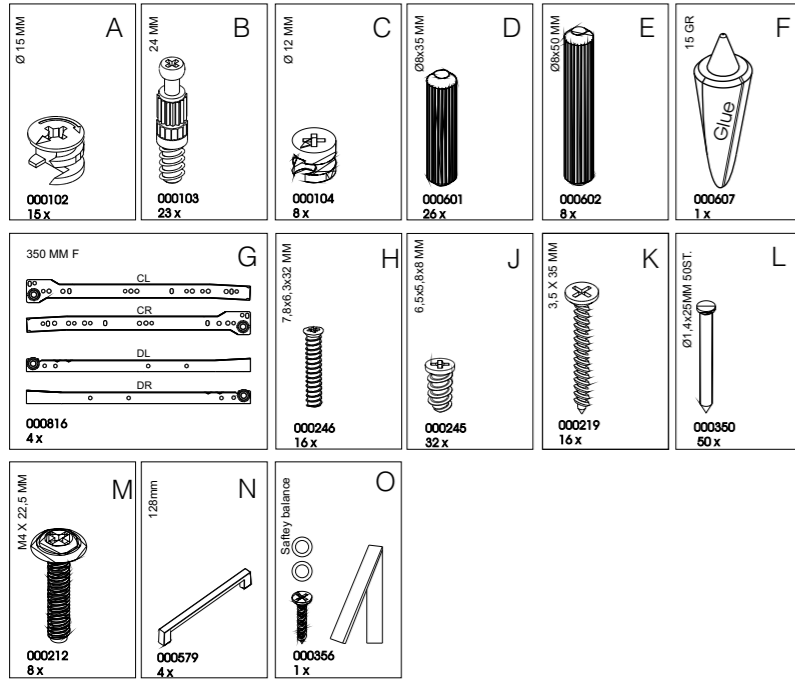
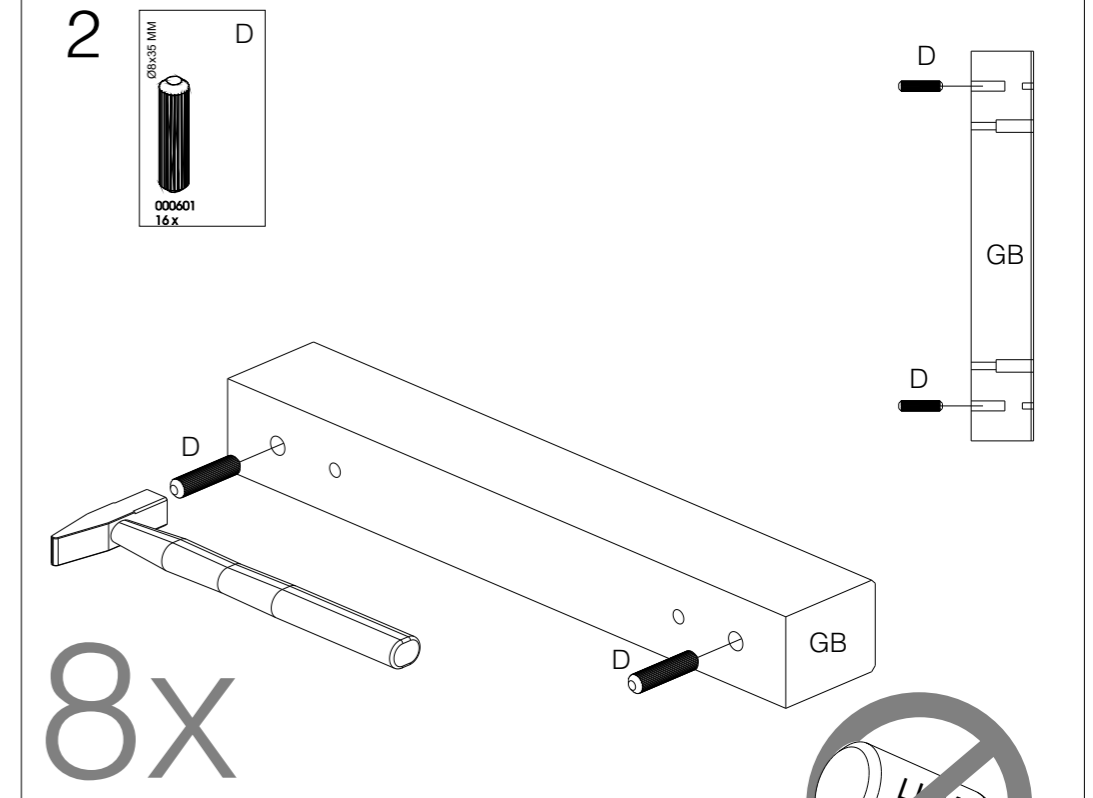
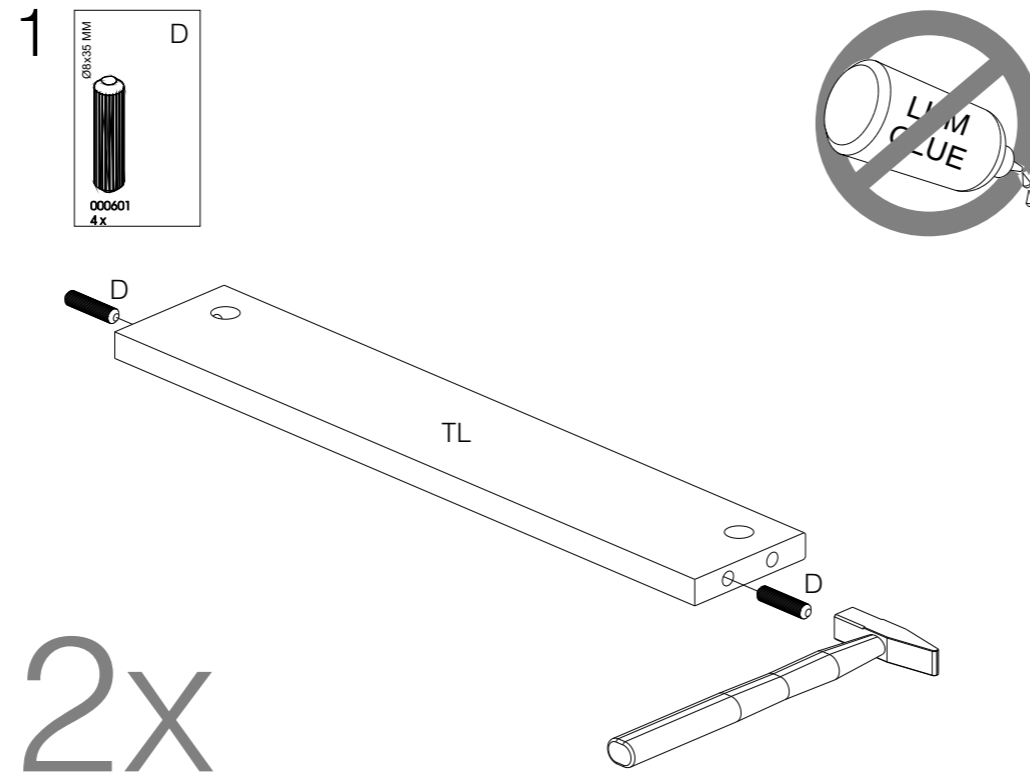
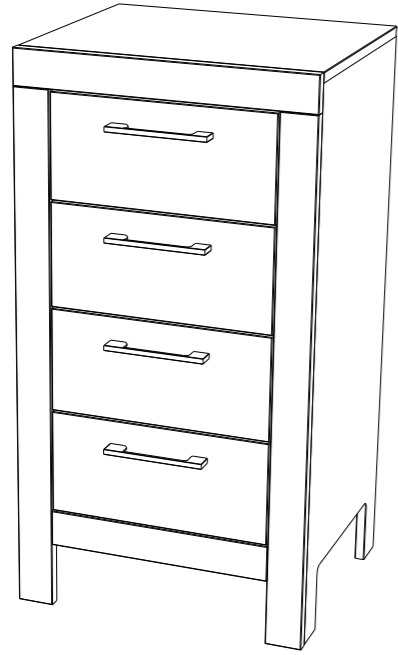

Zaadmarkt 25 1681 PD Zwaagdijk-Oost NL

www.wood.nl

4

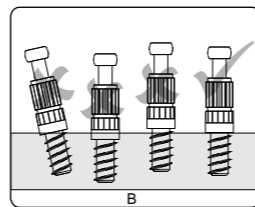
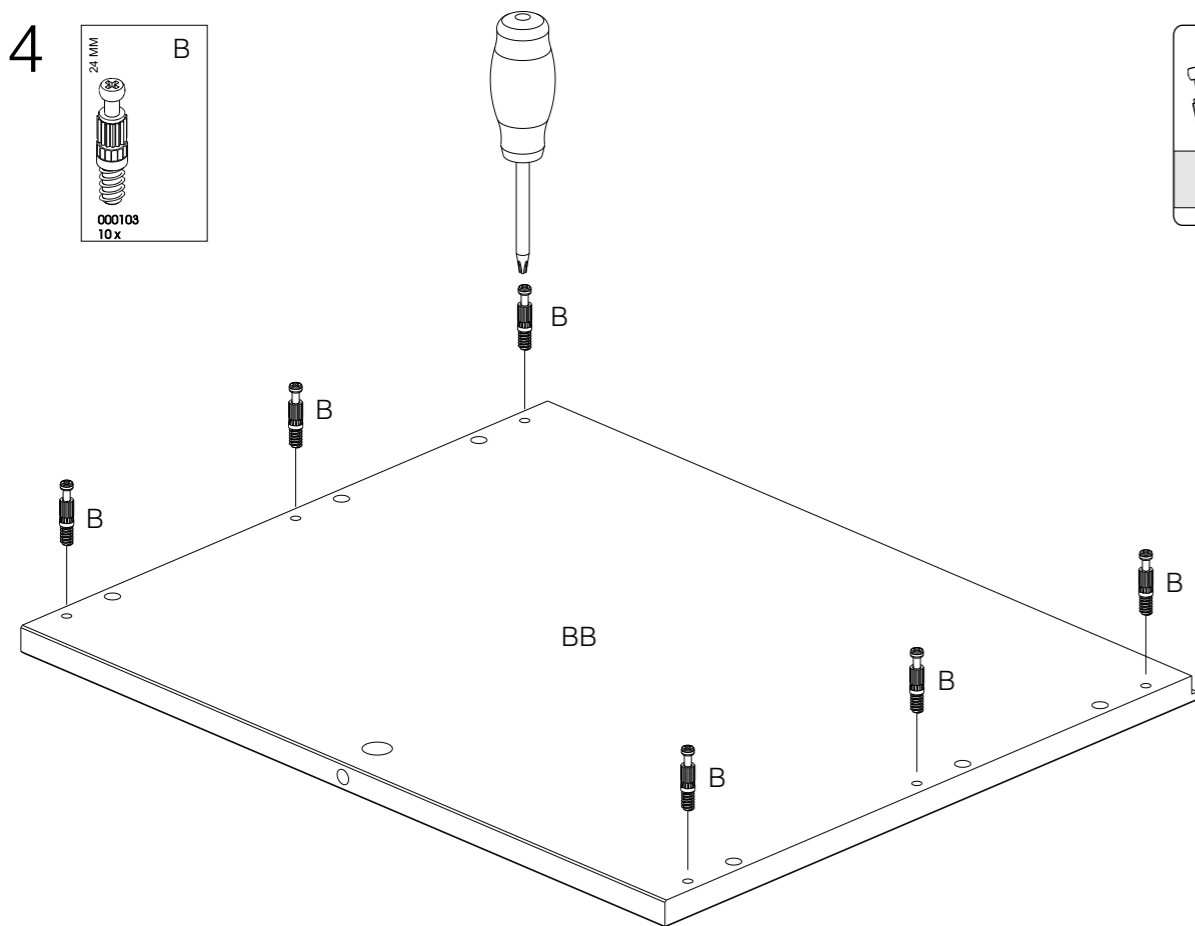
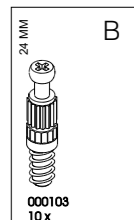

5

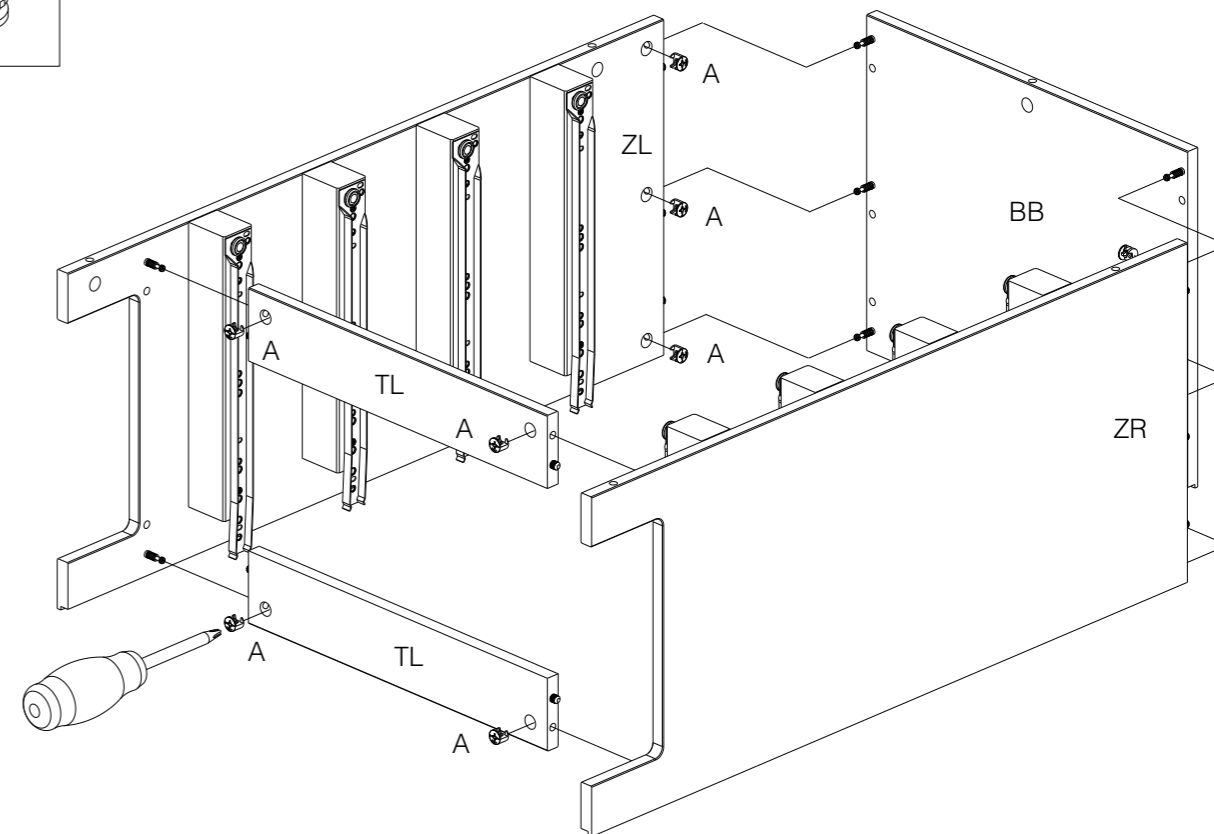
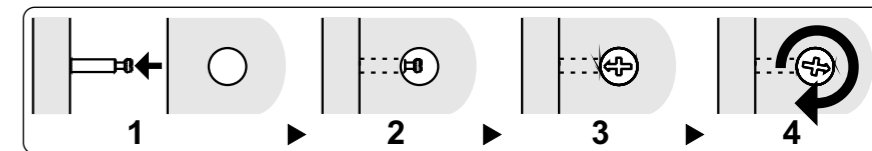
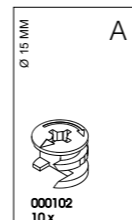

6

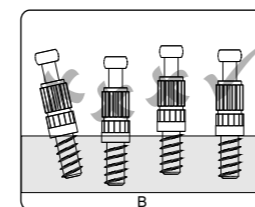
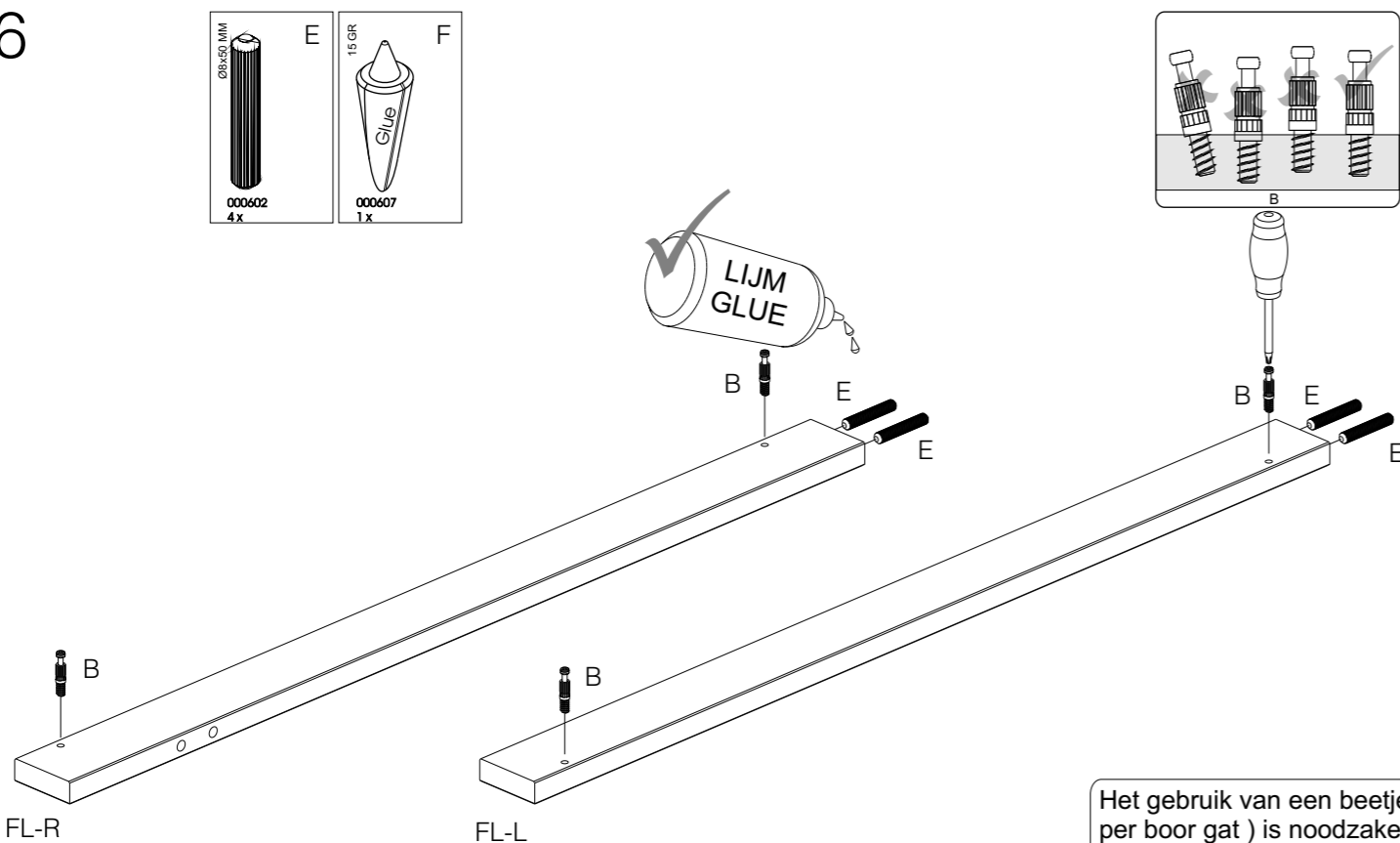
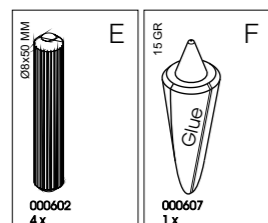

7

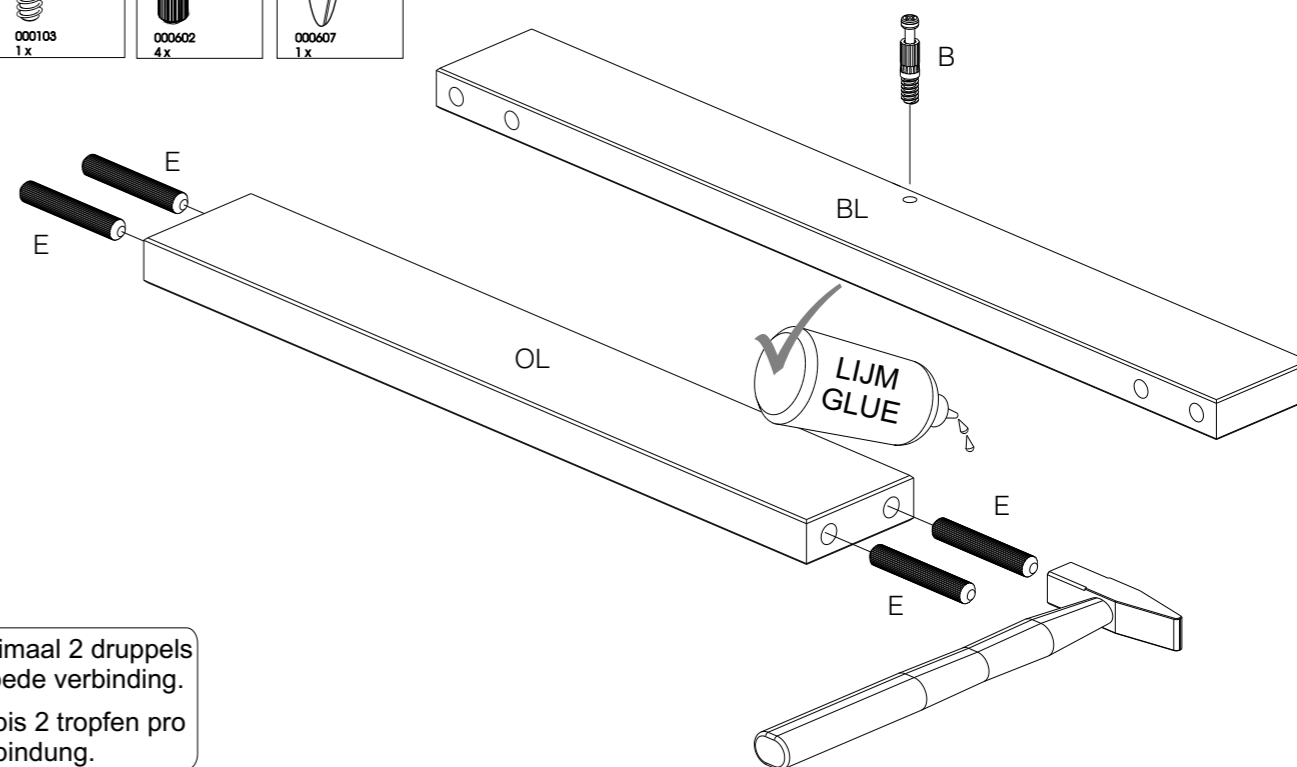
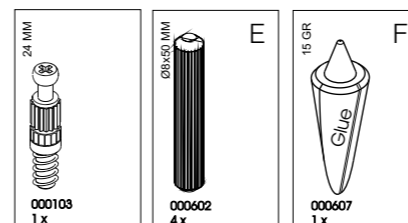

Het gebruik van een beetje houtlijm (maximaal 2 druppels per boor gat) is noodzakelijk voor een goede verbinding.
Verwendung von ein bisschen Holzleim (bis 2 tropfen pro Bohrloch) ist notwendig für eine gute Verbindung.

8

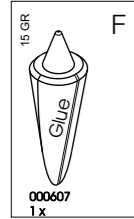

Het gebruik van een beetje houtlijm (maximaal 2 druppels per boor gat) is noodzakelijk voor een goede verbinding.
 Verwendung von ein bisschen Holzleim (bis 2 tropfen pro Bohrloch) ist notwendig für eine gute Verbindung.

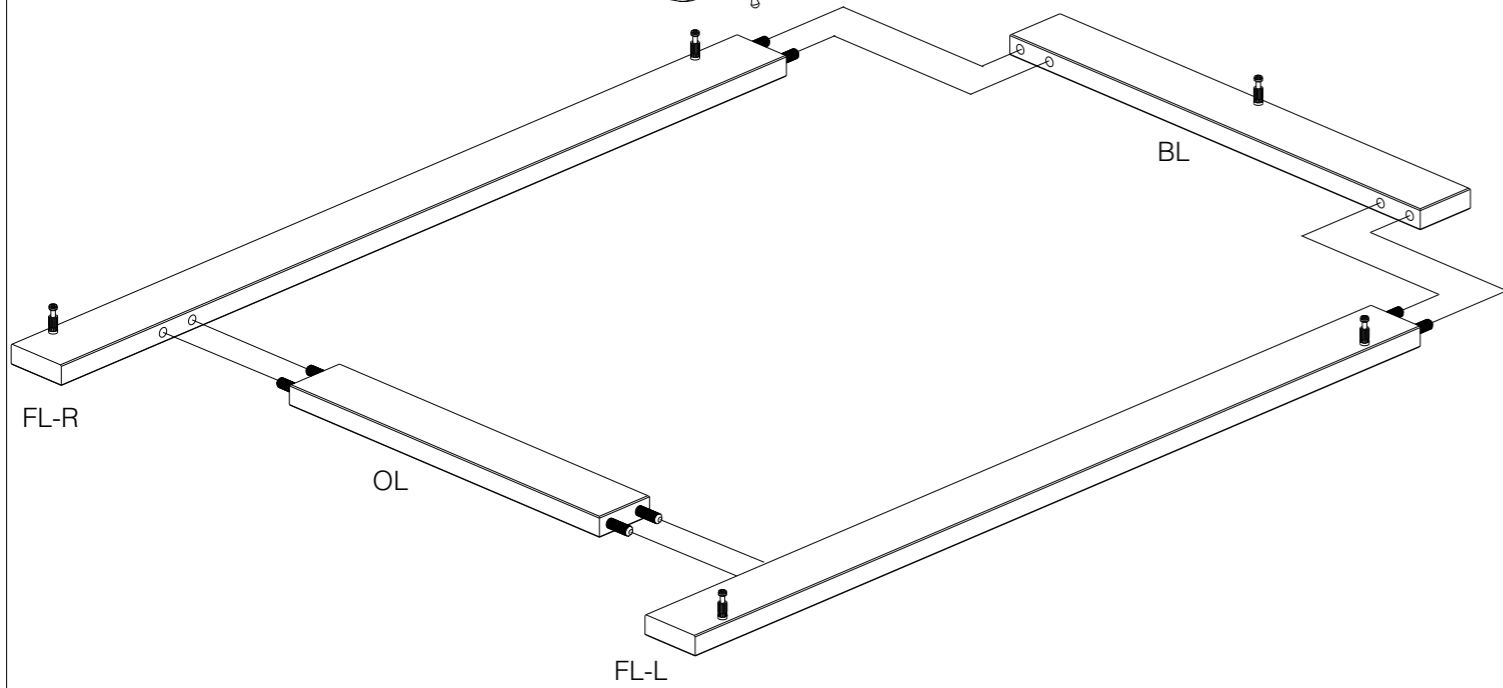

9

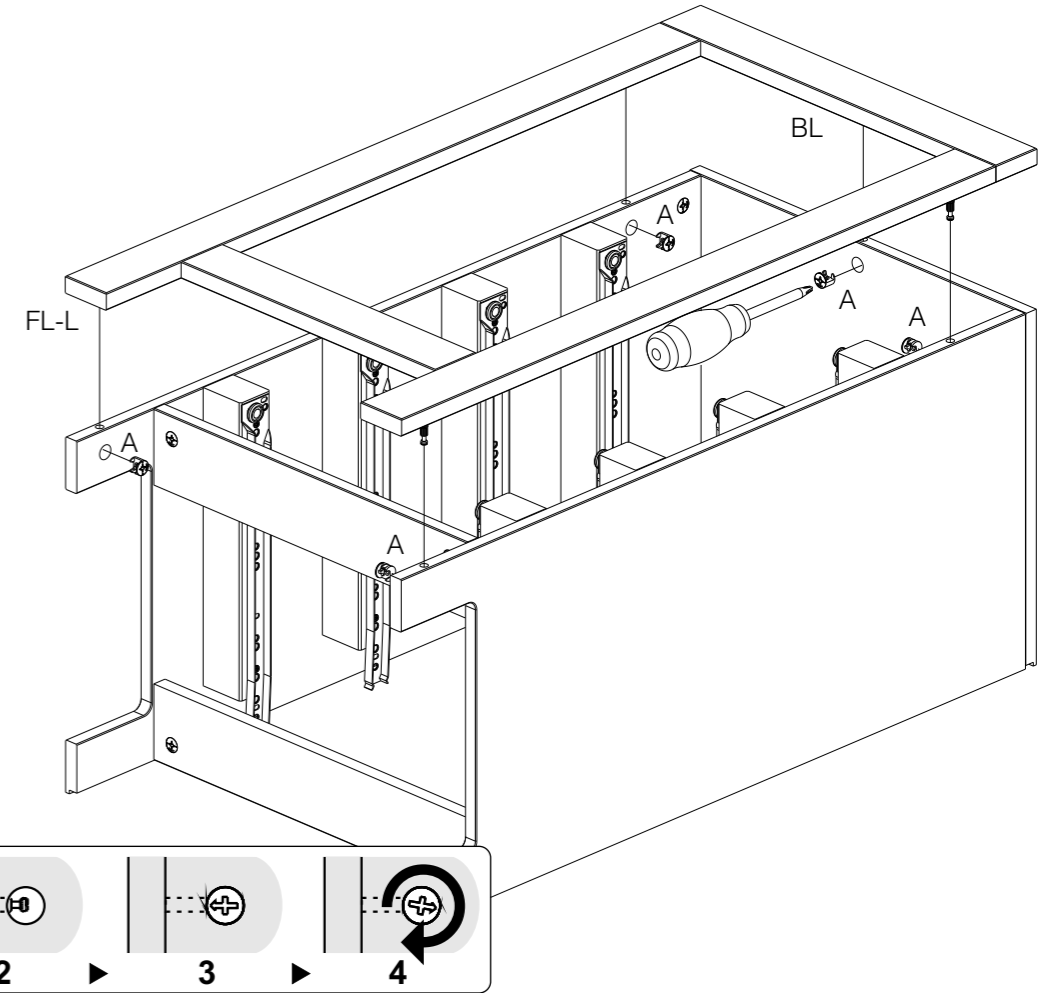
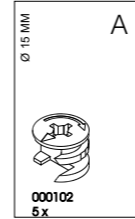

10

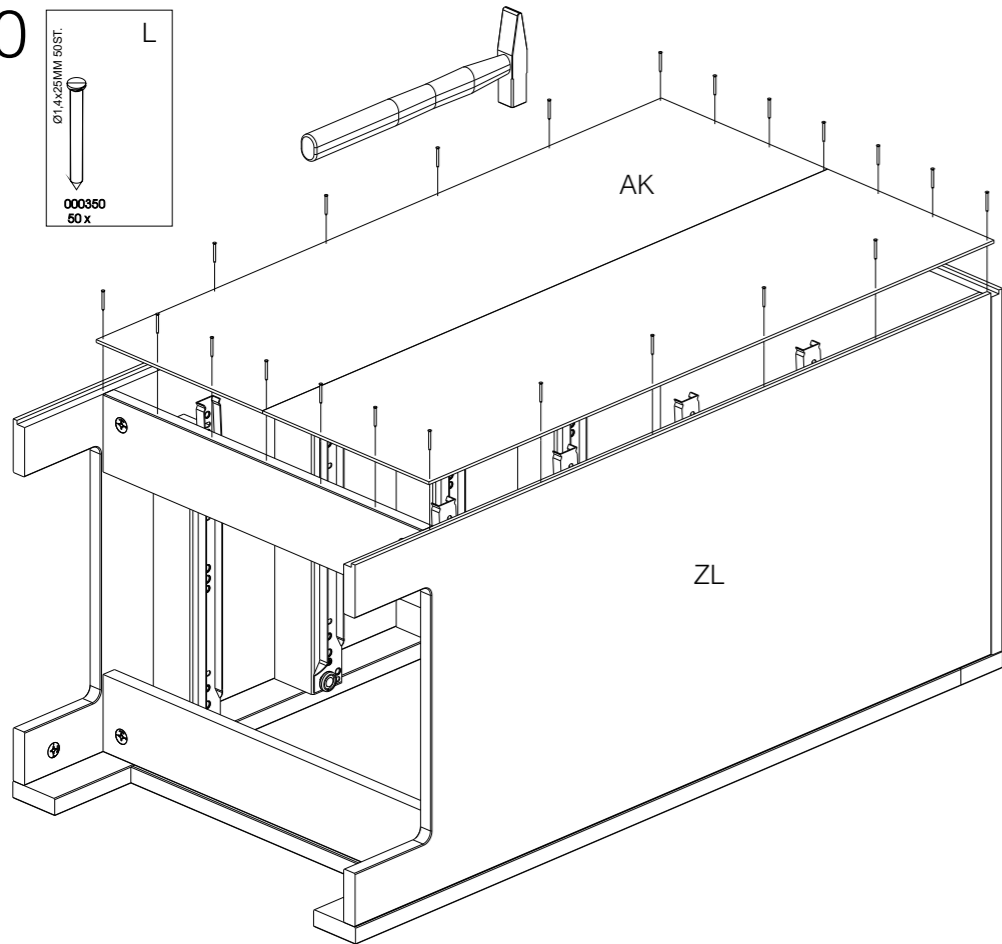
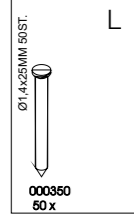

11

